

Duo 20 M

Dual-stage rotary vane pumps with a pumping speed up to 24 m³/h :



Similar Image

Duo 20 M, 1-phase motor, 200-230 V, 50 Hz; 200-240 V, 60 Hz

- Dual-stage, high-performance rotary vane pump with a pumping speed up to 24 m³/h
- With Single-phase motor
- Integrated gas ballast and HV safety valve
- For all low and medium vacuum applications
- Magnetically coupled
- Special feature: Various motor voltages for worldwide employment

M = Magnetically coupled

MC = Corrosive gas version, magnetically coupled

TF = Temperature sensor

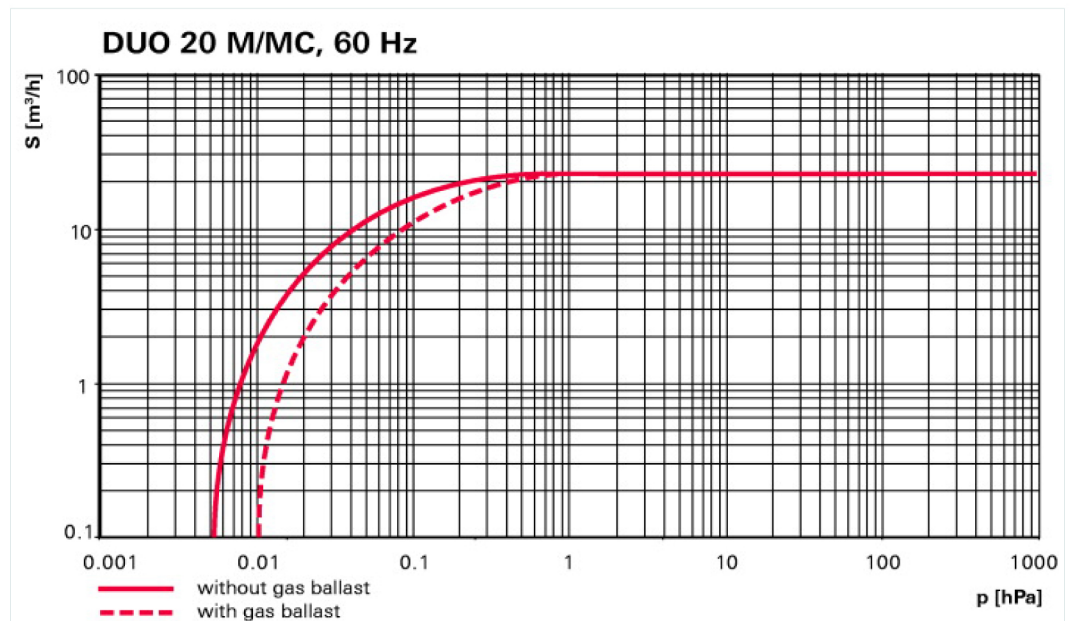
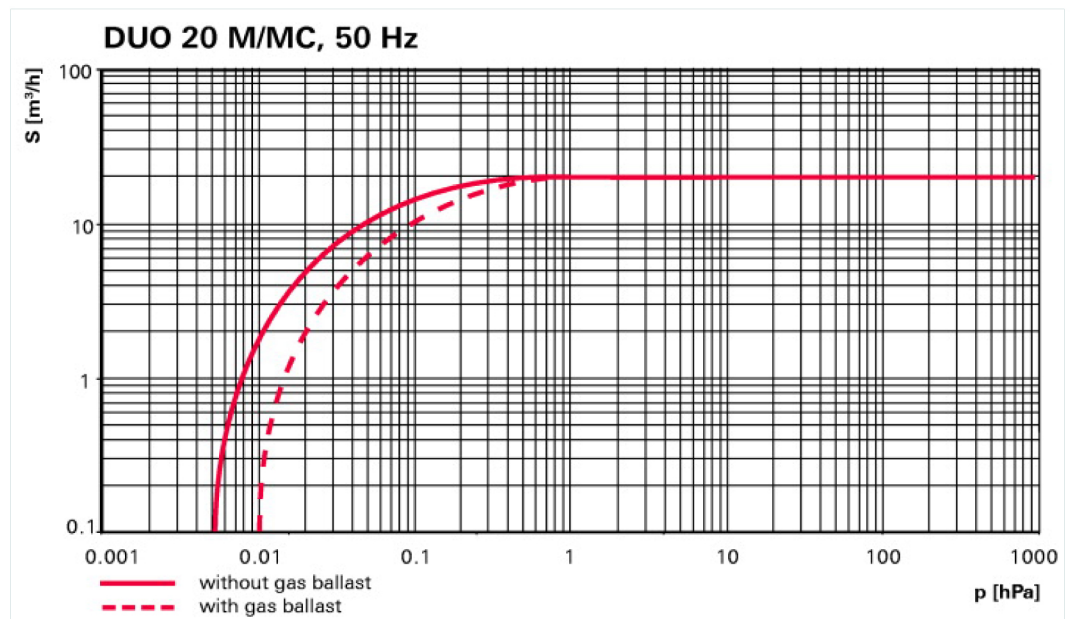

Dimensions

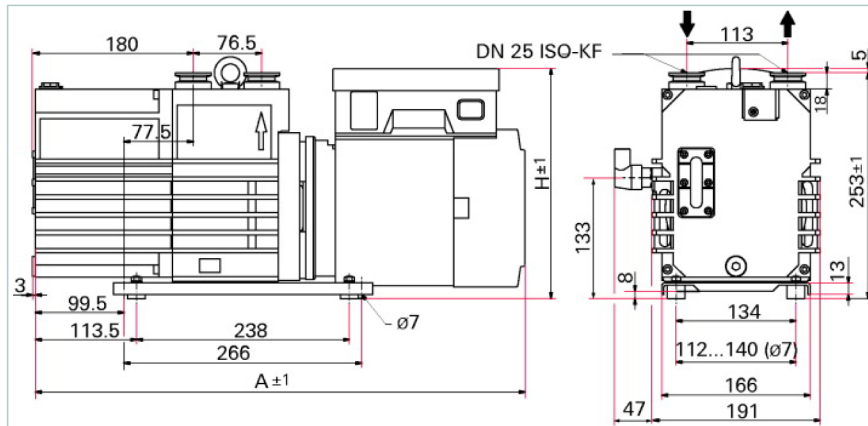

A	551 mm
H	262 mm

Technical Data	Duo 20 M, 1-phase motor, 200-230 V, 50 Hz; 200-240 V, 60 Hz
Ambient temperature	12-40 °C 53.6-104 °F 285-313 K
Cooling method, standard	Air
Emission sound pressure level without gas ballast at 50 Hz	≤ 57 dB (A)
Exhaust pressure, max.	1,500 hPa 1,125 Torr 1,500 mbar
Exhaust pressure, min.	250 hPa 187.5 Torr 250 mbar
Flange (in)	DN 25 ISO-KF
Flange (out)	DN 25 ISO-KF
Leak rate safety valve	≤ 1 · 10 ⁻⁵ Pa m ³ /s ≤ 7.5 · 10 ⁻⁵ Torr l/s ≤ 1 · 10 ⁻⁴ mbar l/s
Magnetic coupling	yes
Mains cable	yes
Mains requirement: voltage (selectable)	100-110, 50 Hz; 100-120, 60 Hz V
Mains requirement: voltage 50 Hz	200-230 (± 5 %) V
Mains requirement: voltage 60 Hz	200-240 (± 5 %) V
Operating fluid	P3
Operating fluid filling	1.1 l
Protection category	IP 54
Pumping speed at 50 Hz	20 m ³ /h
Pumping speed at 60 Hz	24 m ³ /h
Rated power 50 Hz	0.75 kW
Rated power 60 Hz	0.90 kW
Rotation speed at 50 Hz	1500 min ⁻¹
Rotation speed at 60 Hz	1800 min ⁻¹
Switch	Yes, with 2 m cable and safety plug
Ultimate pressure with gas ballast	4 · 10 ⁻³ hPa 3 · 10 ⁻³ Torr 4 · 10 ⁻³ mbar
Ultimate pressure without gas ballast	2 · 10 ⁻³ hPa 1.5 · 10 ⁻³ Torr 2 · 10 ⁻³ mbar
Weight	44 kg 97 lb

Typical ultimate pressure according to PNEUROP

Order number

Duo 20 M

PK D63 712

Accessories	
Accessories	
FAK 025, activated carbon filter	PK Z30 006
Oil return unit from ONF 16 M to Duo 5 M, from ONF 25 M to Duo 10 M, from ONF 25 L to Duo 20 M, standard version	PK 196 172 -T
ONF 25 L, oil mist filter for pumping speeds of up to 30 m ³ /h	PK Z40 158
ZFO 025, zeolite trap	PK Z70 006
Accessories UnoLine	
KAS 25 L, condensate separator for pumping speeds up to 34 m ³ /h	PK Z10 033
KLF 025, cold trap	PK Z80 006
Oil pressure switch for Duo 5/10/20 M and Penta 20/35	PK 196 484 -T
Operations monitoring unit 1 for Duo 1.6/3/6/11 and Duo 5/10/20 M	PK 196 157 -T
Operations monitoring unit 2 for Duo 1.6/3/6/11 and Duo 5/10/20 M	PK 196 142 -T
Operations monitoring unit 3 for Duo 1.6/3/6/11 and Duo 5/10/20 M	PK 196 141 -T
SAS 25, DN 25 ISO-KF, polyester filter	PK Z60 508
URB 025, catalytic trap, 115 V	PT U10 761
URB 025, catalytic trap, 230 V	PT U10 760
Accessories UnoLine Plus	
PTC-resistor tripping device	P 4768 051 FQ
Consumables	
P3, mineral oil, 1 l	PK 001 106 -T
P3, mineral oil, 5 l	PK 001 107 -T
P3, mineral oil, 20 l	PK 001 108 -T

A PASSION FOR PERFECTION

**Vacuum solutions
from a single source**

Pfeiffer Vacuum stands for innovative and custom vacuum solutions worldwide, technological perfection, competent advice and reliable service.

**Complete range
of products**

From a single component to complex systems: We are the only supplier of vacuum technology that provides a complete product portfolio.

**Competence in
theory and practice**

Benefit from our know-how and our portfolio of training opportunities! We support you with your plant layout and provide first-class on-site service worldwide.

Are you looking for a
perfect vacuum solution?
Please contact us:



42 à 48 Bd de Polangis - BP 260
94502 Champigny-sur-Marne - Cedex
☎ 01 48 83 21 76 - 📠 01 48 83 51 01
info@cloup.fr www.cloup.fr