

VACUUM PUMP SYSTEM SC 920 G

DATA SHEET E 296



Technical features

- Automatic, accurate recognition and monitoring of the boiling point using the integrated ramp function
- High recovery rates even with low boiling point solvents
- Integrated gas ballast valve
- Speed-controlled
- Quiet operation
- Optimized suction capacity
- PPS pump head combined with PTFE-coated diaphragm are ideal for aggressive/corrosive gases and vapors

Technical data

Flow rate [m ³ /h] at atm. pressure	1.26
Flow rate [l/min] at atm. pressure	21
Ultimate vacuum [mbar abs.]	2.0 < 5.0 with gas ballast valve in use
Nominal voltage [V]	100 – 240
Frequency [Hz]	50 – 60
Power P ₁ [W]	max. 135
Operating current [A]	max. 1.7
With overcurrent protection and main fuse	

OTHER DATA

Total weight [kg]	15.2
Hose connections:	
– pneumatic	ID 10
– for coolants	ID 8
– for inert gas	ID 6
Dimensions W x H x D [mm]	366 x 423 x 294
Gas ballast valve	Yes
Size of the separators [ml]	500
USB connection	Mini-USB
Permissible media and ambient temperature [°C]	+5 ... +40

MATERIALS

Pump head	PPS
Diaphragm	PTFE-coated
Valves	FFPM
Separators	plastic-coated glass

Dimensions

SC 920 G

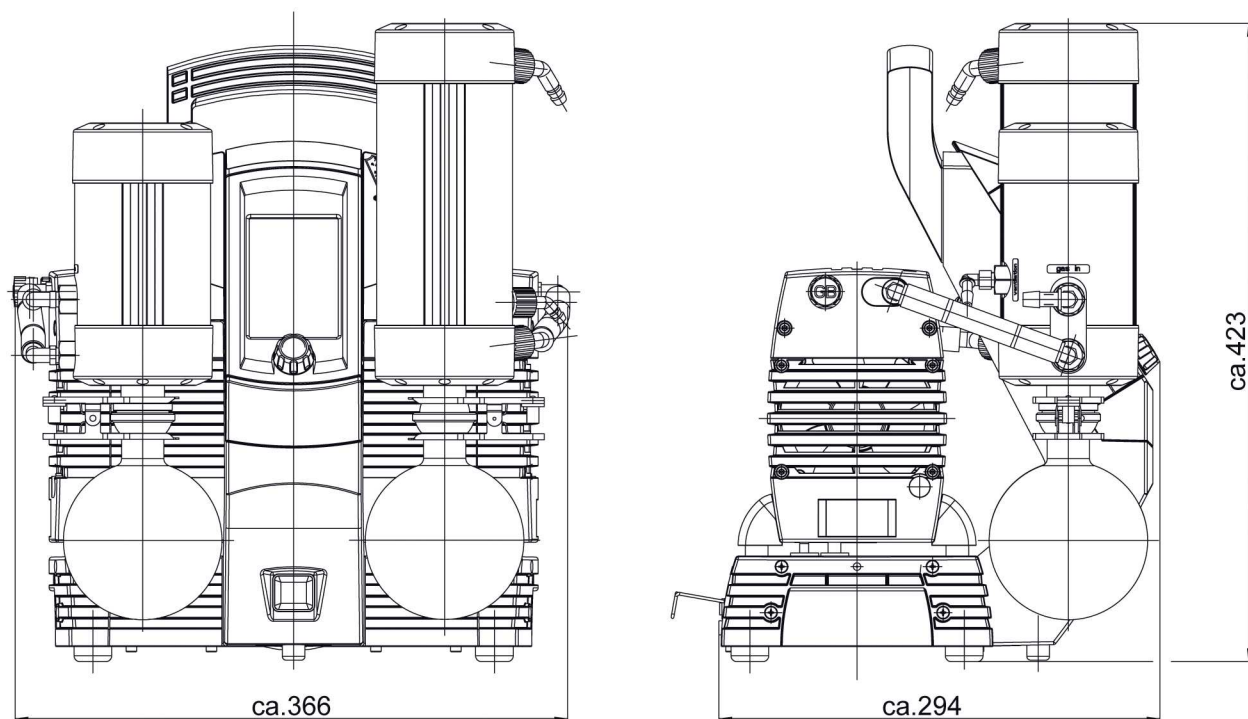

ACCESSORIES

Coolant valve – G 1/2, ID 8
Chemical-resistant protective film

ID

117121
117407

Combination possibilities



Votre revendeur :



42 à 48 bd de Polangis - BP 260
94502 Champigny-sur-Marne - Cedex

☎ 01 48 83 21 76 - 📠 01 48 83 51 01
info@cloup.fr www.cloup.fr