

# VACUUM PUMP SYSTEM LABOPORT® SR 840 G



## Technical features

- Vacuum system comprising chemically resistant diaphragm vacuum pump, base plate and two separator flasks on suction and pressure side
- Modular expandable
- 100% oil-free transfer – thereby pure transferring, evacuation and compression of gases
- High level of vapor and condensate compatibility
- Ideal for extremely aggressive / corrosive gases and vapors
- Integrated gas ballast valve
- 3-color status display for in operation / stand-by / error
- Integrated rotational speed control
- Environmentally friendly
- Start against ultimate vacuum of the pump

## Technical data

Flow rate [m <sup>3</sup> /h] at atm. pressure	2.04
Flow rate [l/min] at atm. pressure	34
Ultimate vacuum [mbar abs.]	6.0
Operating pressure [bar]	0.1
Voltage [V]	100 – 240
Frequencies [Hz]	50/60
Protection class	IP30
Power P <sub>i</sub> [W]	100
Operating current [A]	0.6 (240 V AC) 1.0 (100 V AC)
With thermal switch and power fuse	

## MATERIALS

Pump head	TFM™ PTFE
Diaphragm	PTFE-coated
Valves	FFPM

## OTHER DATA

Weight [kg]	13.1
Hose connections	Inlet: For hose ID 8 – 9,5 Outlet: For hose ID 10
Dimensions W x H x D [mm]	299 x 250 x 274
Permissible media and ambient temperature [°C]	+5 to +40

## SPARE PARTS

	ID
Spare parts kit pump N 840 G	331052
Spare parts kit System*	331056

\*Includes spare parts kit ID 331052 + additional O-Rings for a service of the complete system

## Possible combinations

When combined with the VC 900 vacuum control unit and the connection cable, the rotational speed is controlled in accordance with the requirements of the process. Ideal for combining with all common vacuum controllers with valve control.



## Dimensions

SR 840 G

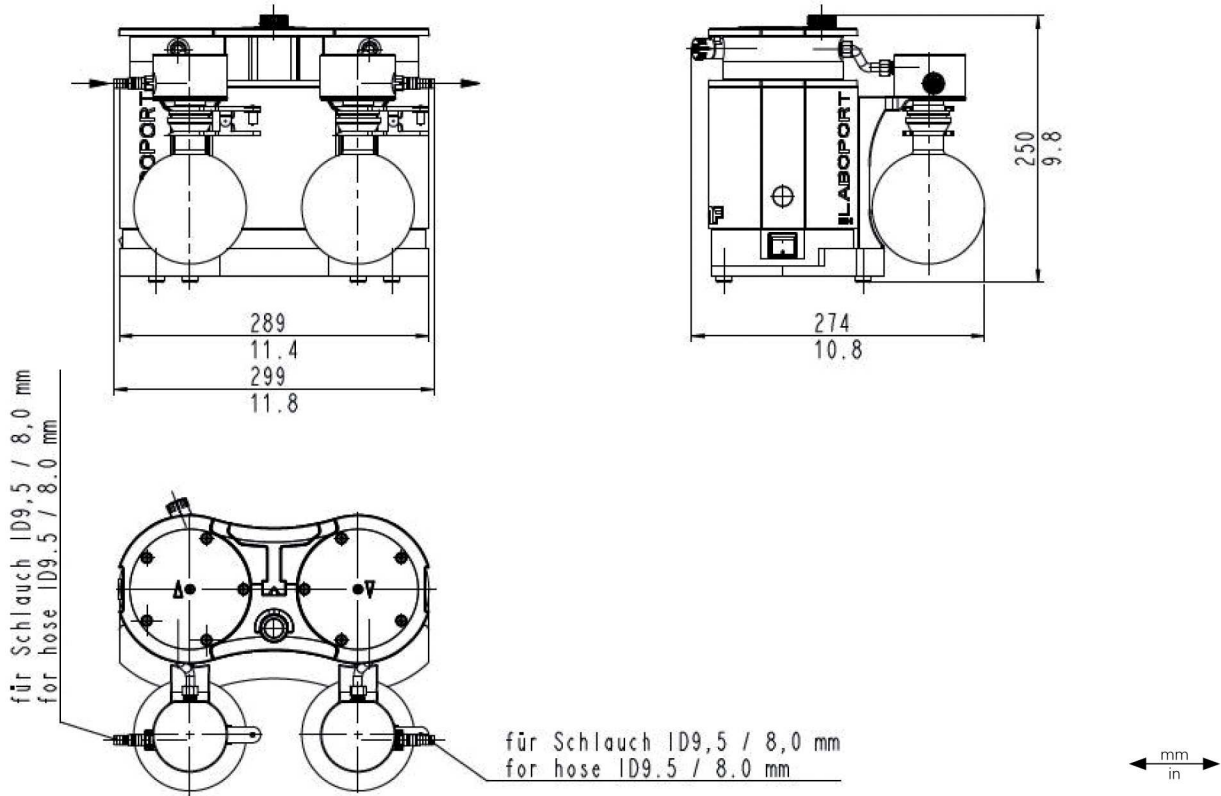

## Performance Characteristics

PUMP DOWN TIME FOR 20 LITER RECEIVER

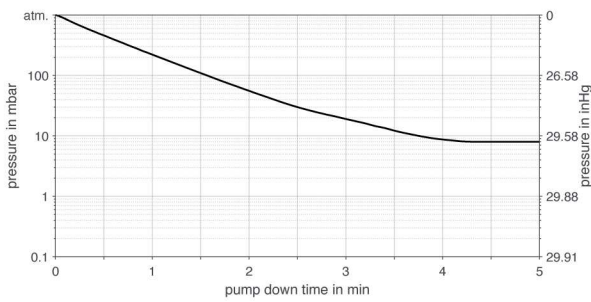

SUCTION PUMPING SPEED AT MIN./MAX. MOTOR SPEED

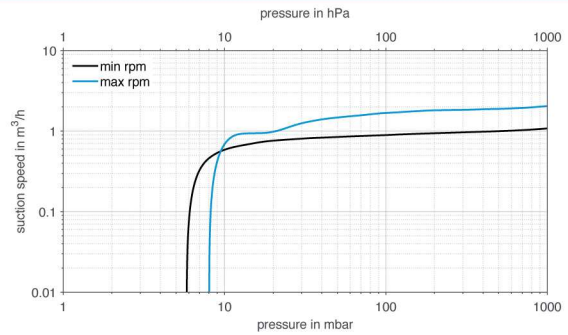

ACCESSORIES	ID
Separator flask	047729
Hose connector with O-ring (FPM)	323609
Hose connector PP (for hose ID 10)	026237
Screw connection cap red, GL 18 (for hose connector ID 026237)	025980
Hose connector PP (for hose ID 8)	025981

Screw connection cap red, GL 14 (for hose connector ID 025981)	025982
Key for hose connector	316279
Connection cable (for combination with VC 900) 2 m	323829
Connecting cable (for combination with VC 900) 5 m	323830
Hose-BGR for Separator flask (2x for SR 840 G)	323095
Hose connector Y-piece - ID10	026432

VOTRE REVENDEUR :



42 à 48 Bd de Polangis - BP 260 - 94502 Champigny-sur-Marne Cedex  
Tél.: 01 48 83 21 76 - Fax.: 01 48 83 51 01 [info@cloup.fr](mailto:info@cloup.fr) [www.cloup.fr](http://www.cloup.fr)